

FITTING INSTRUCTION

Clamp mark in acc. with		Cables joining
ISO	PN	
1	L	Left directional lights
2	+	Rear fog lights
3	31	Ground
4	R	Right directional lights
5	58R	Right side parking lights
6	54	Stoplights
7	58L	Left side parking lights

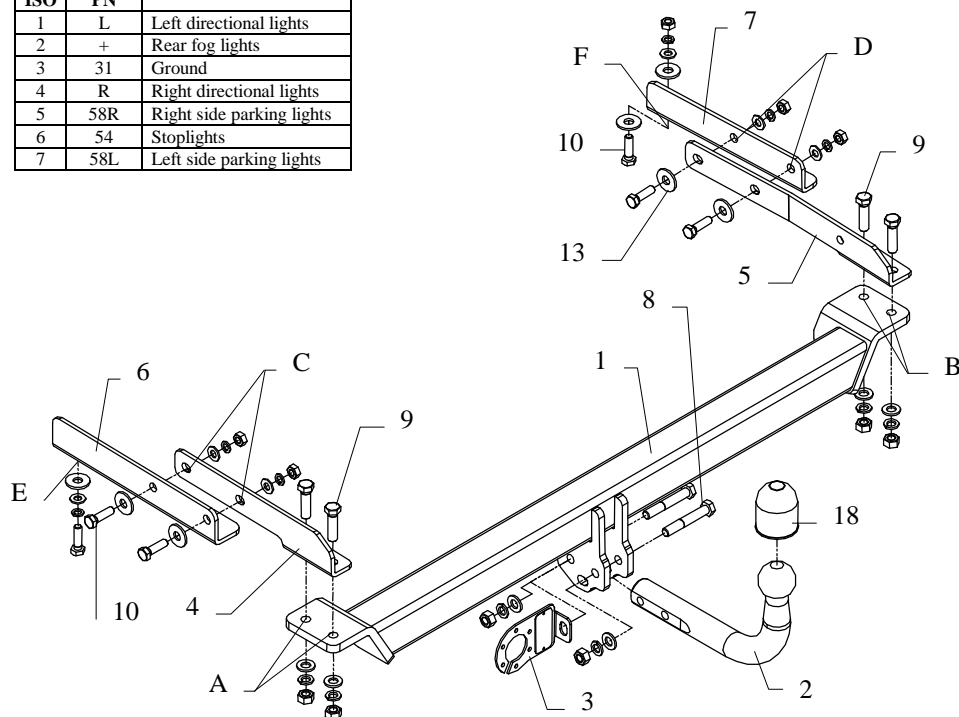

This towbar is designed to assembly in following cars:
MERCEDES C208, W202, S202, C Class, CLK, 4 door, ESTATE,
 produced since 11.1993 till 05.2002, catalogue no. **D14** and is prepared to
 tow trailers max total weight **1800 kg** and max vertical mass **75 kg**.

From manufacturer

Thank you for buying our product. Their reliability has been confirmed in many tests. Reliability of towbar depends also on correct assembly and correct exploitation. For this reasons we kindly ask to read carefully this instruction and apply to hints.

The towbar should be install in points described by a car producer.

The instruction of the assembly

- To install this towbar, make following actions:
 - remove all items from boot floor,
 - disconnect a battery,
 - in estate version - disassemble plastic covers from the left and right side of the chassis (only) for elements pos. 4, 5, 6, and 7.
- Find original marked holes on the left and right side of the chassis and drill holes $\varnothing 15\text{mm}$ in points A and B. For better orientation you can put main bar of the towbar (pos. 1).
- Next put elements pos. 4 and 6 on the left side and pos. 5 and 7 on the right side (inside boot) and fix it through point A and B using bolts M12x45mm (pos. 9) and through holes C and D by bolts M10x35mm (pos. 10).
- To fix elements 6 and 7 through points E and F, drill original marked holes using bit $\varnothing 12\text{mm}$. Next fix elements using bolts M10x35mm (pos. 10)
- Fix tow-ball (pos. 2) and socket plate (pos. 3) using bolts M12 x 75 mm (pos. 8) from accessories.
- Tighten all bolts according to the torque shown in the table.
- Connect electric wires of 7-poles socket according to the instruction of the car. (Recommend to make at authorized service station)
- Complete paint layer damaged during installation.

Torque settings for nuts and bolts (8,8):	
M 8 - 25 Nm	M 10 - 55 Nm
M 12 - 85 Nm	M 14 - 135 Nm









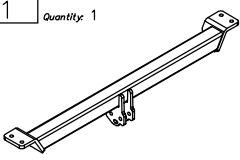
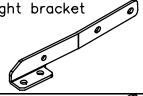

NOTE

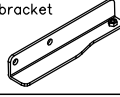
After install the towbar you should get adequate note in registration book (at authorised service station). The car should be equipped with:

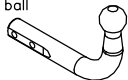
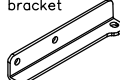
- Indicators
- Tow mirrors

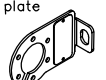
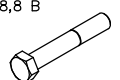
After 1000km of exploitation check all bolts and nuts. The ball of towbar must be always kept clear and conserve with a grease.

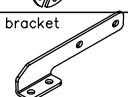
Towbar accessories:

Pos. 1	Name: Main bar Quantity: 1	Pos. 5	Name: Right bracket Quantity: 1	Pos. 10	Name: Bolt 8,8 B Quantity: 6 Dim.: M10x35mm	Pos. 15	Name: Plain washer Quantity: 6 Dim.: Ø 10,5 mm
							
		Pos. 6	Name: Left bracket Quantity: 1	Pos. 11	Name: Nut 8 B Quantity: 6 Dim.: M12	Pos. 16	Name: Spring washer Quantity: 6 Dim.: Ø 12,2 mm
							
Pos. 2	Name: Tow ball Quantity: 1	Pos. 7	Name: Right bracket Quantity: 1	Pos. 12	Name: Nut 8 B Quantity: 5 Dim.: M10	Pos. 17	Name: Spring washer Quantity: 6 Dim.: Ø 10,2 mm
							
Pos. 3	Name: Socket plate Quantity: 1	Pos. 8	Name: Bolt 8,8 B Quantity: 2 Dim.: M12x75mm	Pos. 13	Name: Plain washer Quantity: 7 Dim.: Ø32xØ12x3mm	Pos. 18	Name: Ball cover Quantity: 1
							
Pos. 4	Name: Left bracket Quantity: 1	Pos. 9	Name: Bolt 8,8 B Quantity: 4 Dim.: M12x45mm	Pos. 14	Name: Plain washer Quantity: 6 Dim.: Ø 13 mm		
							



PPUH AUTO-HAK S.J.

Produkcja Zaczepów Kulowych
Henryk & Zbigniew Nejman
76-200 SŁUPSK ul. Słoneczna 16K
tel/fax (059) 8-414-414; 8-414-413
E-mail: office@autohak.com.pl
www. autohak.com.pl

Towing hitch (without electrical set)

Class: **A50-X** Cat. no. **D14**

Designed for:

Manufacturer: **MERCEDES**

Model: **C208, W202, S202, C Class**

Type: **CLK, 4 door, ESTATE**

produced since 11.1993 till 05.2002

Technical data:

D-value: 9,22 kg

maximum trailer weight: **1800 kg**

maximum vertical cup mass: **75 kg**

Approval number according to Directive 94/20/EC: **e20*94/20*0656*00**

Foreword

This towbar is designed according to rules of safety traffic regulations. The towing hitch is a safety component and can be install only by qualified personnel. Any alteration or conversion of the towing hitch is prohibited and would lead to cancellation of design certification. Remove insulating compound and underseal from vehicle (if present) in the area of the matting surfaces of the towing hitch.

The vehicle manufacturer's specifications regarding trailer load and max. vertical cup load are decisive for driving whereat values for the towing hitch cannot be exceeded.

D-value formula:

$$\frac{\text{Max trailer weight [kg]} \times \text{Max vehicle weight [kg]}}{\text{Max trailer weight [kg]} + \text{Max vehicle weight [kg]}} \times \frac{9,81}{1000} = D \text{ [kN]}$$